

ONC Lawyers
柯伍陳律師事務所

IP Strategies for International Businesses:

Patent

Talk for ONC Seminar Series

by Kennex Chan, Associate/Patent Attorney, ONC Lawyers

28th April 2017



The Roadmap

1. [What is a patent?](#)
2. [The protection and value conferred by a patent](#)
3. [What can you patent for your business?](#)
4. [Elements of a patent prosecution](#)
5. [Worldwide strategy](#)
6. [How to build and manage a patent portfolio for your business?](#)
7. [Cost-saving tips in patent prosecution](#)
8. [Defence and enforcement](#)





1. What is a Patent?

What is a Patent?

- **Property rights**
 - Granted by government authorities to inventors
 - Intangible assets
 - Assignable rights
- **Exclusive rights**
 - Rights to exclude others from making, selling, offering to sell, using or importing an invention
 - Time period and regional limitation
 - Private rights
- **Protect and encourage invention**
 - (Limited) monopoly v. public disclosure





What is a Patent?

- **Main kinds of patent:**
 - Utility/invention
 - Device
 - System
 - Method/Process
 - Article/Product by process
 - Utility model (functional design)
 - Design (ornamental design)



What does a Patent Application comprise of?

- Abstract
- Specification
- Drawings
- **Claims** ←
- Prior arts disclosure
- Declarations
- Other paperwork
- **A Priority Date** ←

(19)  (11)  EP 1 887 187 B1

(12) EUROPEAN PATENT SPECIFICATION

(45) Date of publication and mention of the grant of the patent:
30.04.2014 Bulletin 2014/18 (51) Int Cl.:
F01D 5/28 (2006.01) F02K 3/04 (2006.01)

(21) Application number: 07113169.2
(22) Date of filing: 26.07.2007

(54) **Rotor blade**
Rotorschaukel
Aube de rotor

(64) Designated Contracting States:
DE FR GB (74) Representative: Illingworth, William
Illingworth
GPO Europe
GE International Inc.
The Ark
201 Talgarth Road
Hammersmith
London W6 8BJ (GB)

(30) Priority: 31.07.2006 US 461014
(43) Date of publication of application:
13.02.2008 Bulletin 2008/07 (56) References cited:
FR-A1- 2 874 232 GB-A- 1 500 776
GB-A- 2 262 315 US-A- 5 279 892
US-A1- 2003 017 053 US-A1- 2006 120 874
US-B1- 6 431 837

(73) Proprietor: GENERAL ELECTRIC COMPANY
Schenectady, NY 12345 (US)
(72) Inventor: Schilling, Jan Christopher
Middletown, OH 45044 (US)

EP 1 887 187 B1

Note: Within nine months of the publication of the mention of the grant of the European patent in the European Patent Bulletin, any person may give notice to the European Patent Office of opposition to that patent, in accordance with the Implementing Regulations. Notice of opposition shall not be deemed to have been filed until the opposition fee has been paid. (Art. 99(1) European Patent Convention).

Printed by Jouve, 15021 PARIS (FR)

What are NOT Patentable?

- Abstract idea
- Natural phenomena
- Law of nature
- Immoral invention
- Some jurisdictions have different rules for invention in the fields of medicine, healthcare, biogenetic technology, software, business method etc.



What is NOT a Patent?

- Copyrights
 - An original artistic or literary work – such as a publication, painting, audio recording, music, sculpture, software, computer code etc.
- Trademarks
 - Symbol, word, phrase, design or a combination of any of the above that identifies and distinguishes the source of goods/services
- Trade Secret
 - The Coca-Cola formula
- Licence to infringe





2. Protection and Value

Protection

- Monopoly (for what you claimed)

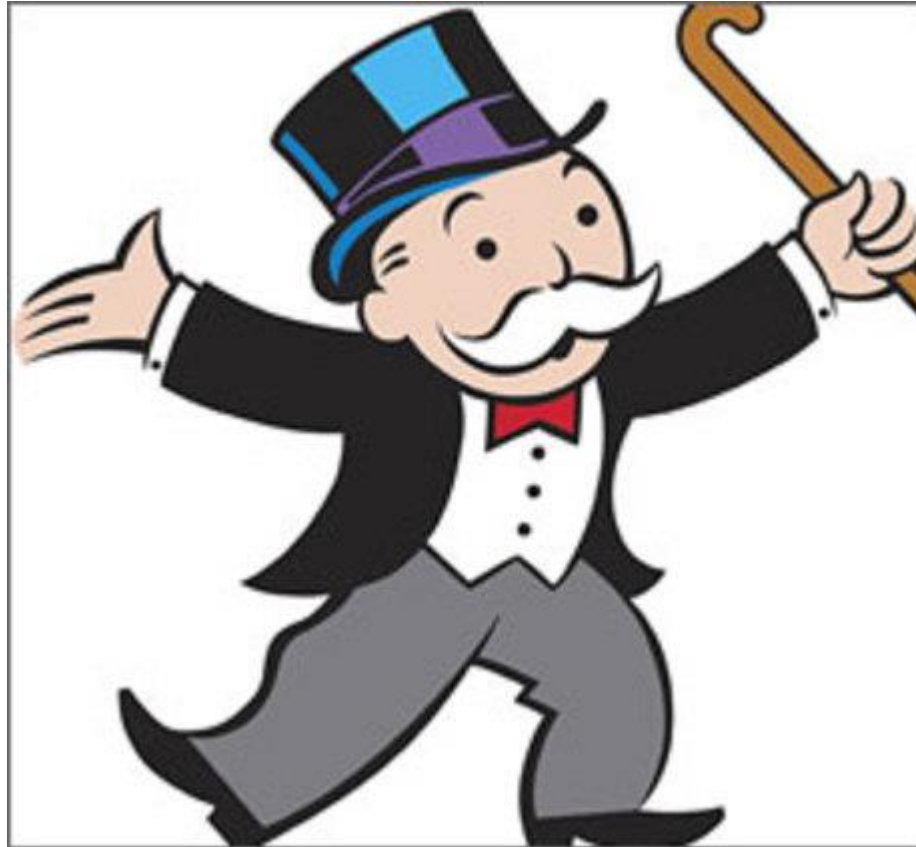



Values

Research and Development

- Exclusive right to exploit the **claimed** invention in a patent
- Blocking competitors' product development

Commercial Values

- Marketing advantage
- “First to market” advantage

Financial Values

- Security for loans
- Licensing/Assigning the rights to a third party
- Selling the patent for money, which is an intangible asset



3. Patent for Your Business

Patent for Your Business



- Identify your key design or technology
- Identify *your competitors'* key design or technology

and many did.



Invention Patent - *Device*

Invention Patent - *Device*

An Actual Device

[US 8523515](#)

Noise reducer for rotor blade in wind turbine

(General Electric Company)

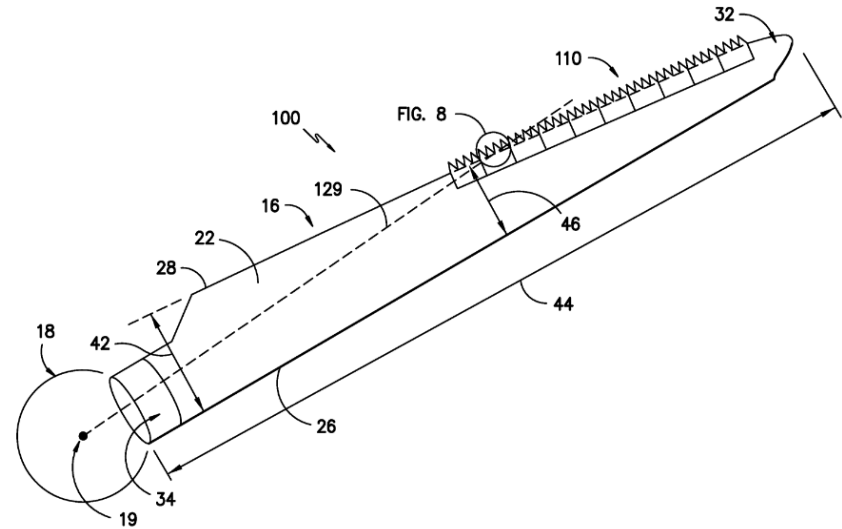

[US 8991383](#)

Convection oven using rack support ducts for air flow

(General Electric Company)

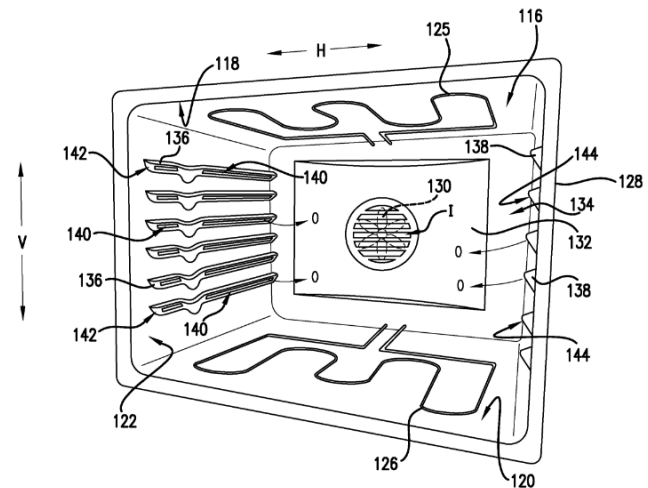

Invention Patent - *Device*

An Actual Device

[US 8465203](#)

Brake systems for C-arm positioning devices

(General Electric Company)

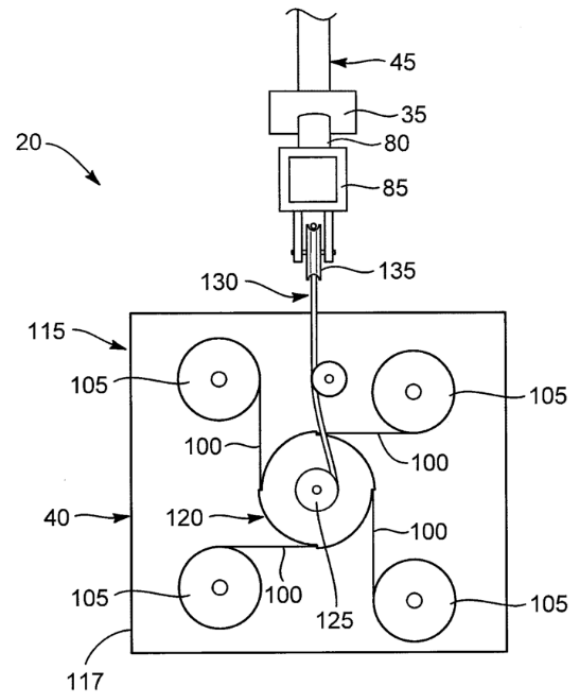
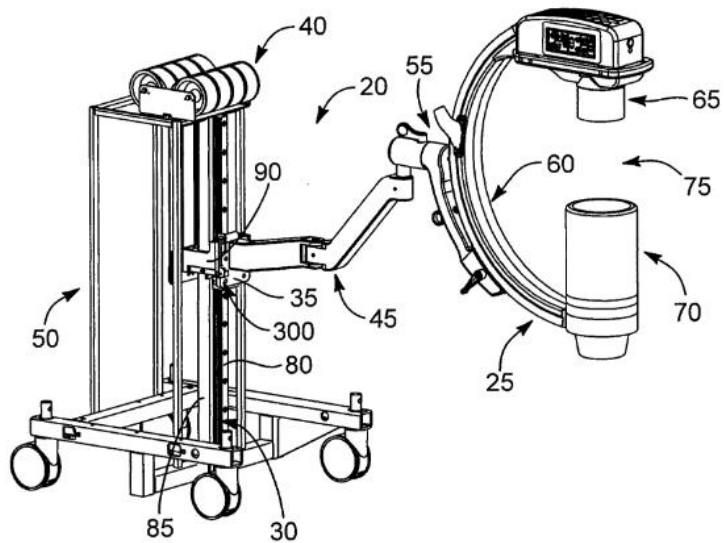

Invention Patent - *Device*

An Actual Device

[US 9039106](#)

Convertible furniture system base and modular applications including armchairs, tables, and storage cabinets

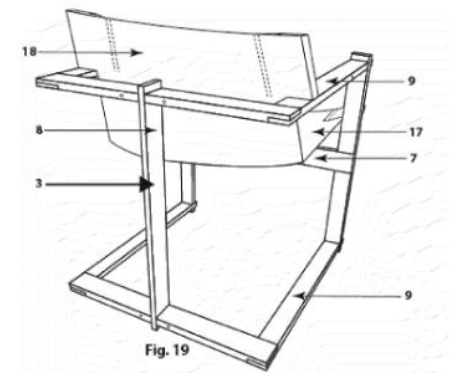
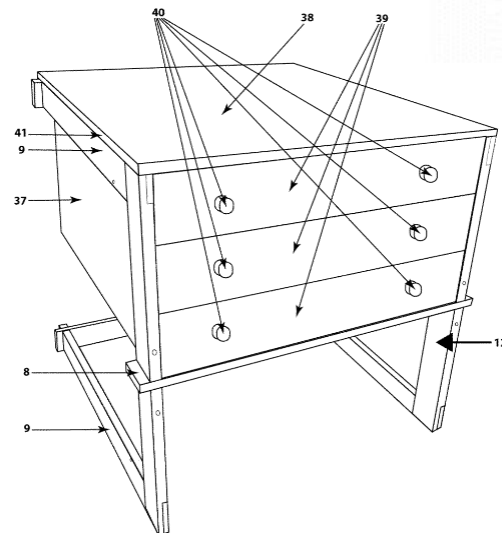
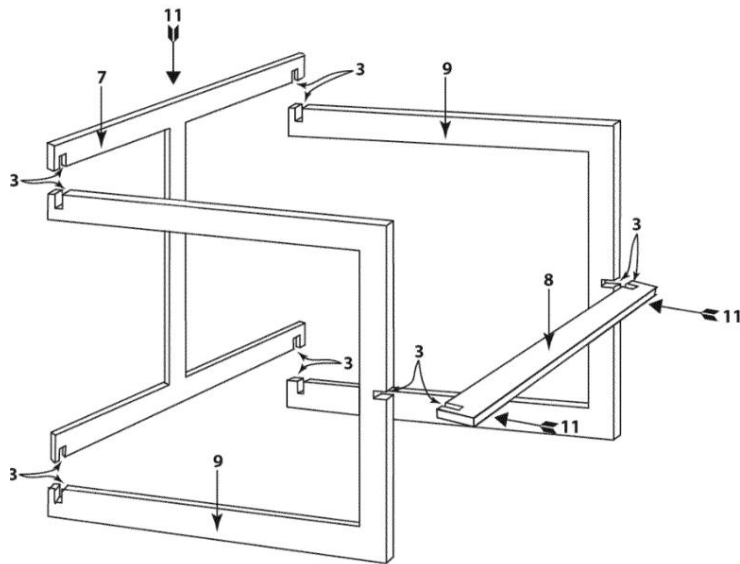



Invention Patent - *Method*

Invention Patent - *Method*

Treatment

[US 8647509](#)

Seawater desalination plant and production of high purity salt

(General Electric Company)

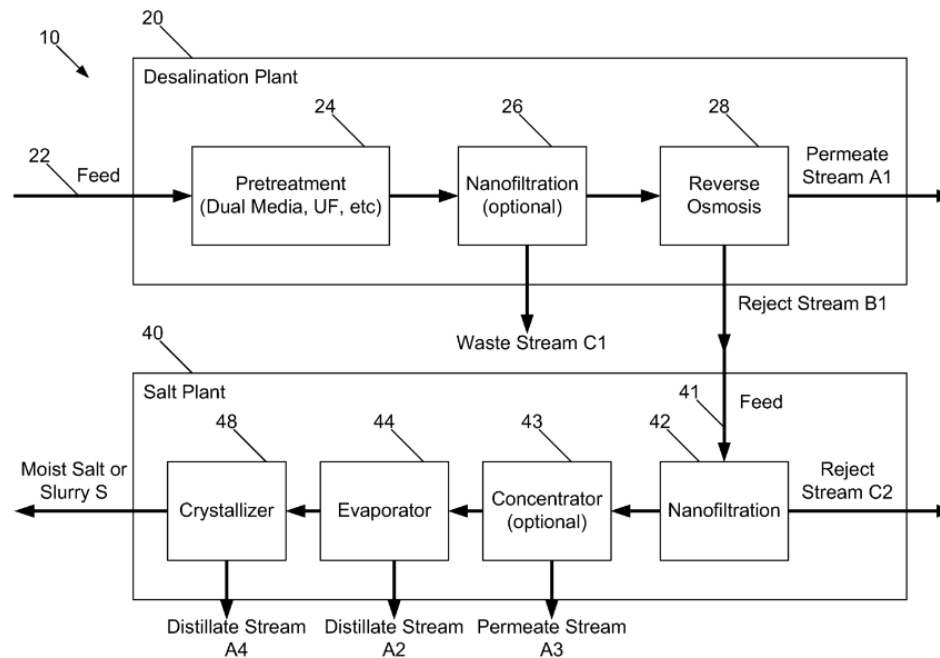

Invention Patent - *Method*

Treatment

[US 5143598](#)

Methods of tar sand bitumen recovery

A method of recovery of bitumen from tar sands comprising the steps of:

- mixing tar sands, an organic solvent effective in solubilizing ... ;
- separating a bitumen-rich solvent phase from ... ; and
- recovering bitumen from the bitumen-rich solvent phase.

[WO 2014007905](#)

Methods for recovering oil and water from oil sands tailings

A method for recovering water and oil from tailings comprising:

- feeding said tailings to a drying apparatus, wherein said tailings are separated to form a concentrated tailings product and a fluid stream; and
- recovering said fluid stream.

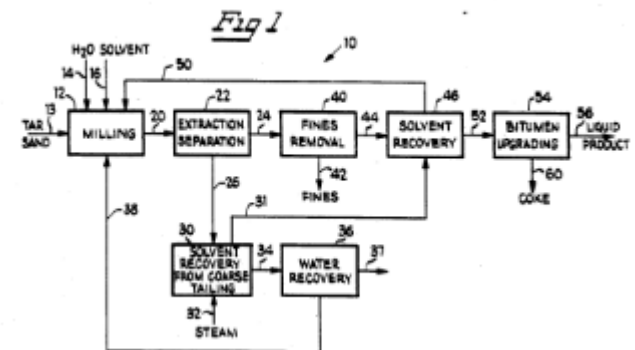

Invention Patent - *Method*

Construction

[US 8429876](#)

Concrete rib construction method

A method of constructing a well-insulated rigid monolithic concrete building using a plurality of T-beams with vertical stem portions and cross-sectional flange portions, said method comprising the steps of:

arranging a plurality of rebars in a vertical arrangement on a foundation;

anchoring the rebars onto the foundation with anchoring elements to form a frame for the walls of the building;

arranging forms in a vertical arrangement;

embedding rigid foam insulation material in between the rebars;

arranging a plurality of reinforcement bars at an angle from the plurality of rebars to form the frame for the roof of the building;

connecting the plurality of rebars and the plurality of reinforcement bars with connecting elements;

arranging forms in the bottom portion of the frame for the roof;

pouring in a concrete mixture to fill voids around the plurality of rebars, forms, and the rigid foam insulation material thereby forming T-beams with vertical stem portions and cross-sectional flange portions to form the walls; and

pouring in a concrete mixture to fill voids around the plurality of reinforcement bars and forms thereby forming T-beams with vertical stem portions and cross-sectional flange portions to form the roof.

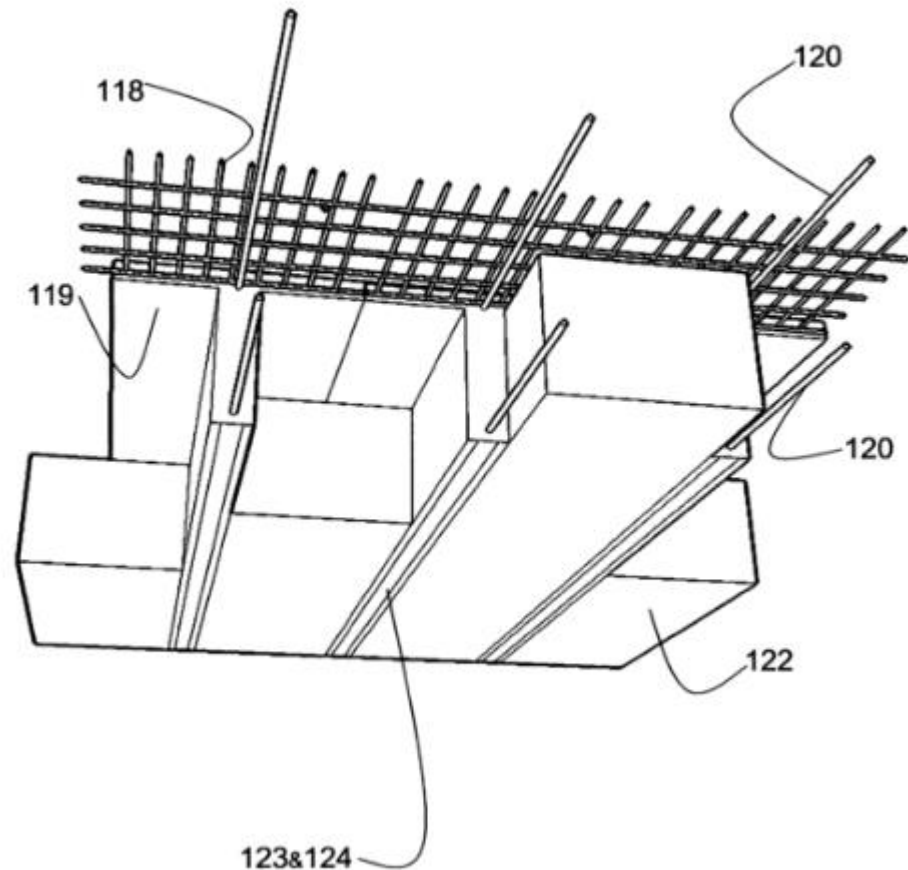

Invention Patent - *Method*

Construction

[US 7031930](#)

Project management for complex construction projects by monitoring subcontractors in real time

(General Electric Capital Corporation)

[EP 1532330](#)

In-situ construction of concrete building

A method of in-situ construction of a reinforced concrete building including:

- first temporarily supporting pre-formed wall members in desired positions on building support means; and
- then casting the building vertical support pillars utilising suitable surfaces of the wall members as formwork for the pillars.

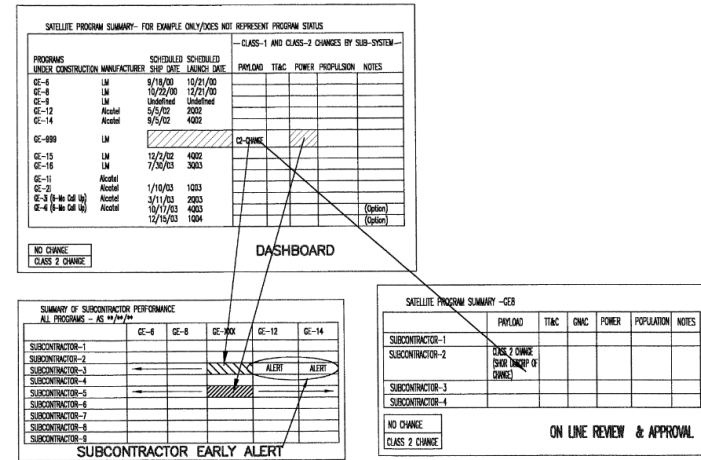

Invention Patent - *Method*

Control System

[US 6170402](#)

Roller coaster control system

(Universal City Studios Inc.)

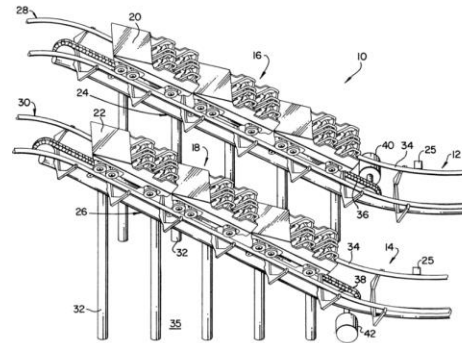

[US 20130325505](#)

Systems and methods for population health management

(General Electric Company)

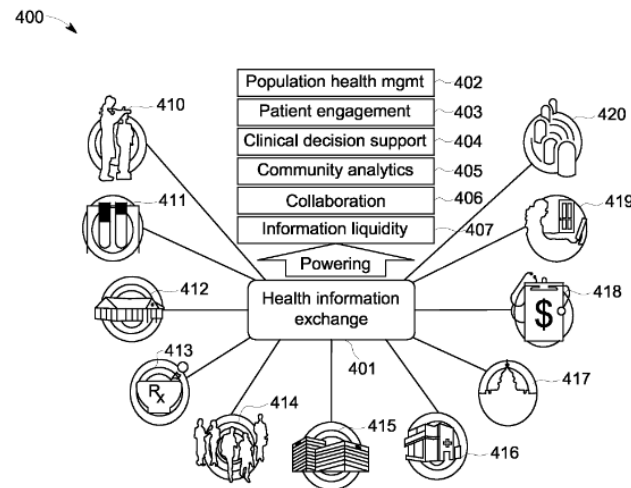

Invention Patent - *Method*

“Software”

[US 8655053](#)

Body modeling and garment fitting using an electronic device

The invention claimed is:

1. A method for obtaining a size measurement of a person to be fitted for a garment, comprising:
 - providing a plurality of digital images from a camera of a portable electronic device, wherein each of the plurality of digital images includes photographic data of a particular body part of a user, the plurality of photographs providing images of the particular body part from a plurality of different aspects;
 - generating a 3-D or contoured computer model of at least a portion of the particular body part by applying a feature extraction technique to the photographic data from the plurality of digital images, wherein generating the computer model includes estimating the size of the particular body part in a plurality of iterations using the photographic data from the plurality of different aspects;
 - calculating an actual size of one or more features of the particular body part;
 - generating a fitting measurement for a garment using the calculated actual size of the one or more features; and
 - providing the fitting measurement to the user.

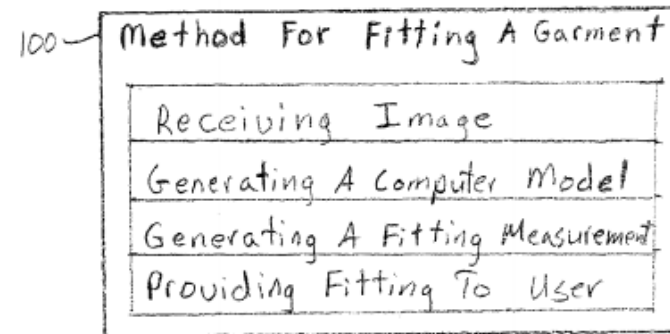

Fig. 1

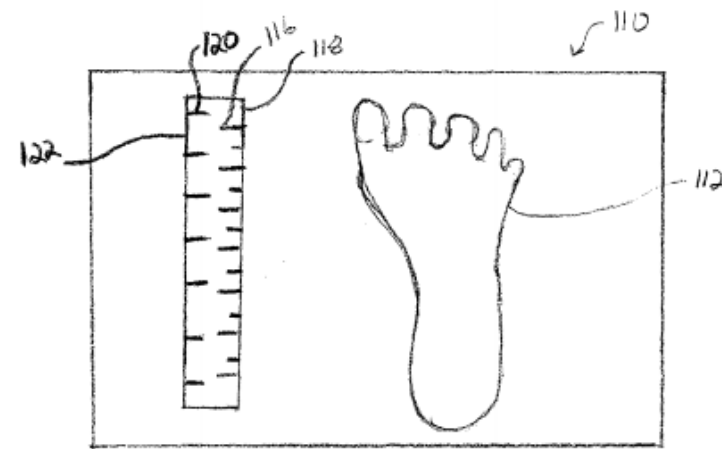

Fig. 2

Invention Patent - *Method*

“Software”

[US 4885844](#)

*Computer aided custom tailoring
with disposable measurement
clothing*

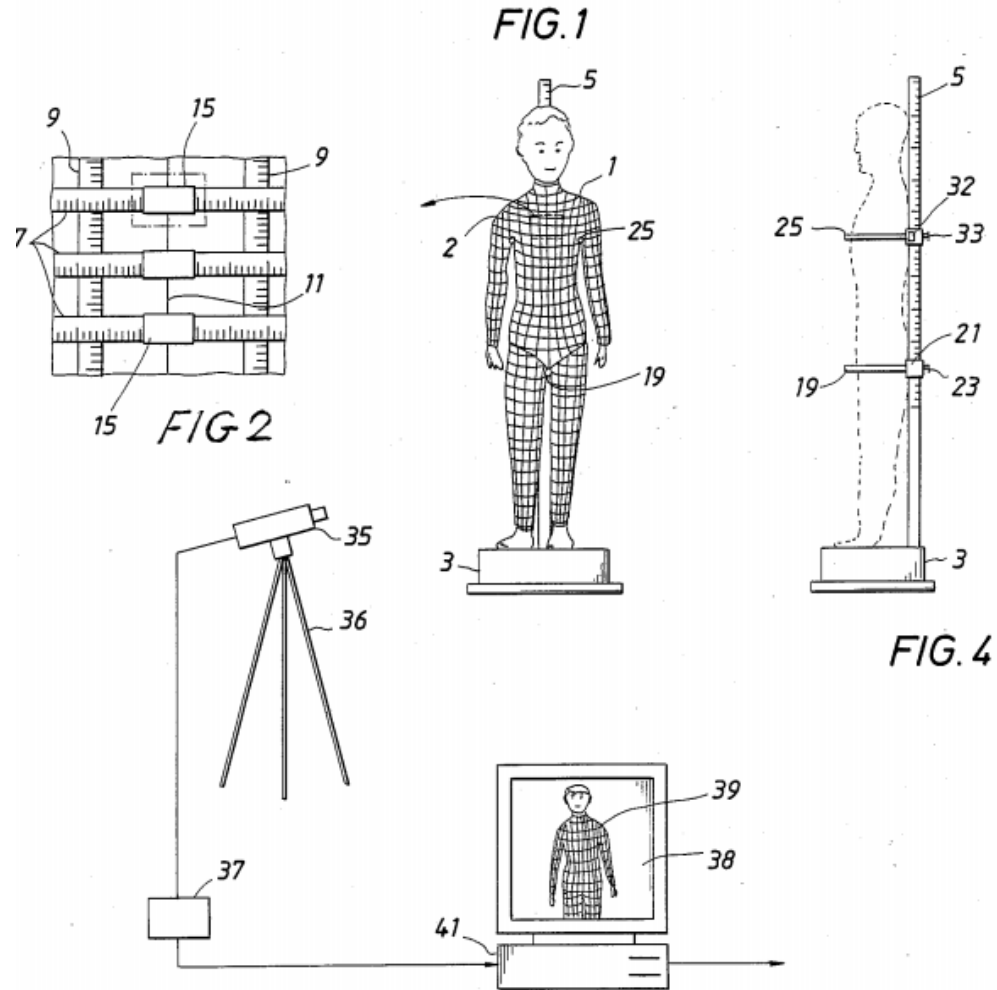

Invention Patent - *Method*

Finance “software”

[US 7689482](#)

System and method for payer (buyer) defined electronic invoice exchange

(JP Morgan Chase Bank, N.A.)

[US 7814073](#)

Utility for identifying differences between two Java objects

(JP Morgan Chase Bank, N.A.)

[US 8468090](#)

Account opening computer system architecture and process for implementing same

(HSBC Technologies Inc.)





Invention Patent – *Product by Process*

Invention Patent – *Product by Process*

Product Manufactured by a New Process

[US 8404296](#)

Product-by-process for manufacturing preparations having an aroma and taste of grilling, char-grilling, charcoal broiled grilling and woodfired grilling

A grilled, charcoal broiled, charcoal grilled or wood-fired flavoring produced by a process comprising the steps of:

- heating at least one oil or fat, in the presence of oxygen;
 - removing vapor generated by said heating from said at least one heated oil or fat; and
 - recovering said vapor in an absorption liquid.
-
- Requirement: new process and unobvious difference
 - Other examples: alloy, chemical



Design Patent

Design Patent

Consumer Products

[US D622996](#)

Pillow-top mattress design

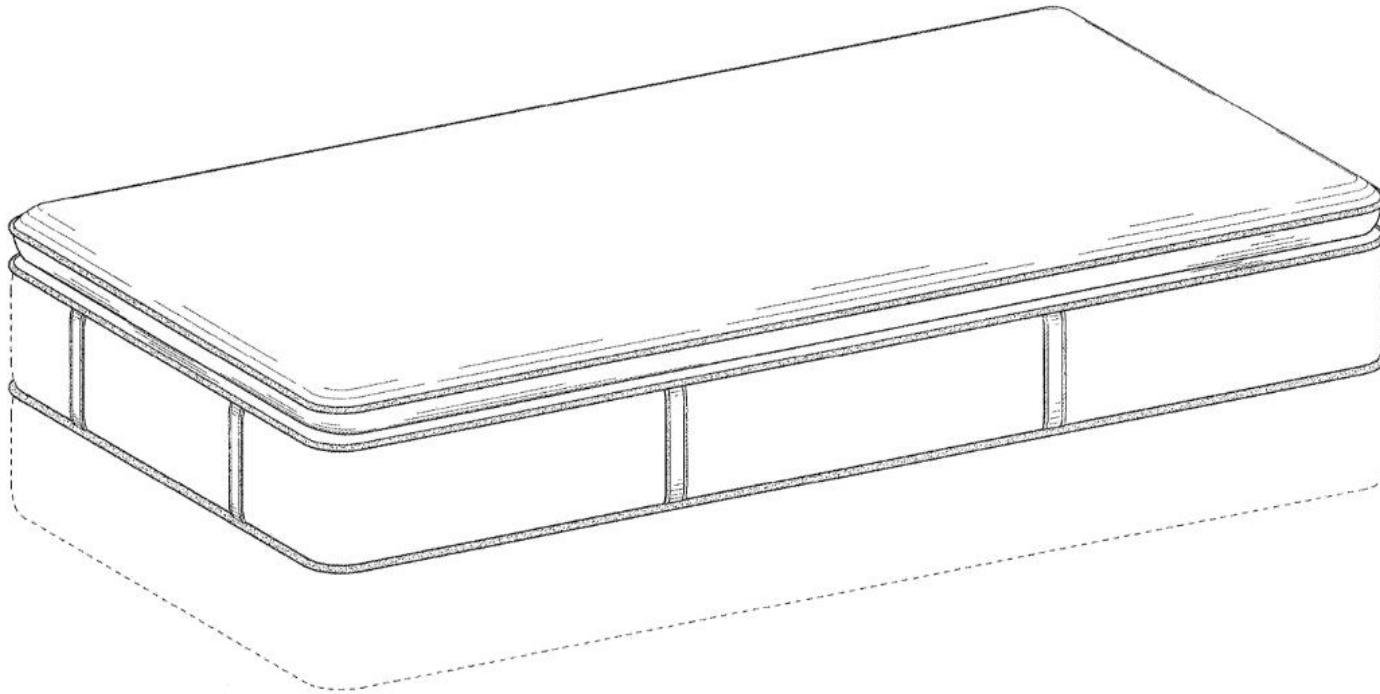

Design Patent

Consumer Products

[US D432018](#)

Bottle

(The Coca-Cola Company)

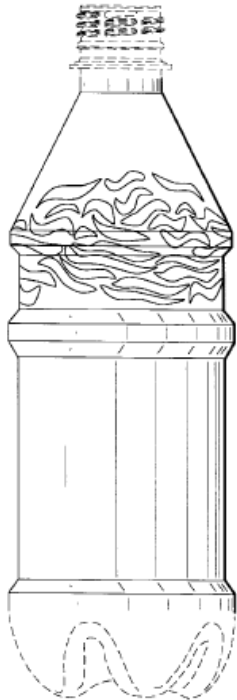

[US D584568](#)

Embossed cup

(The Coca-Cola Company)

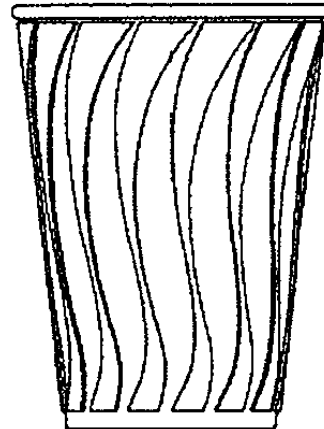

Design Patent

Consumer Products

[US D678871](#)

Smart phone cover with cloth feature

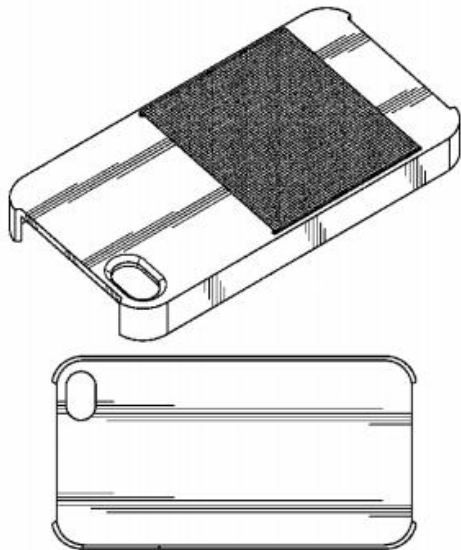

[US D734560](#)

Terry cloth oven mitt with grip

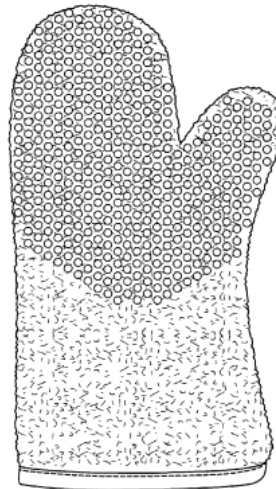

FIG. 1

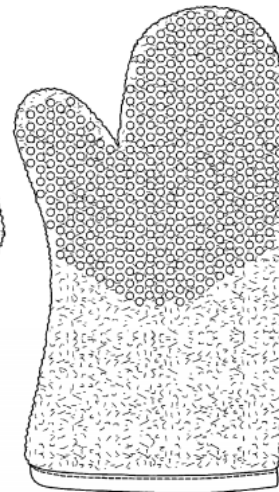

FIG. 2

Design Patent

Consumer Products

[US D625898](#)

T-shirt with attached tie

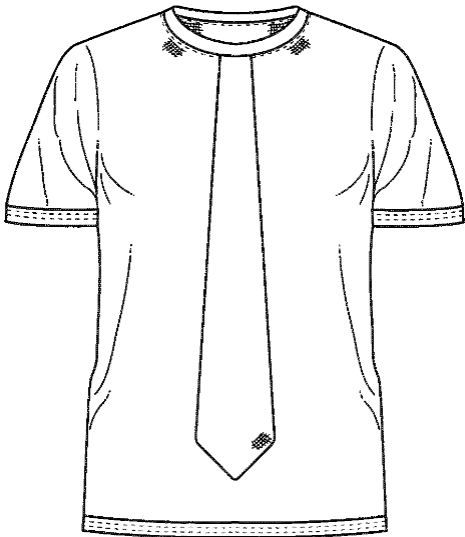

[US D668464](#)

Bar stool



[US D687933](#)

Toilet bowl

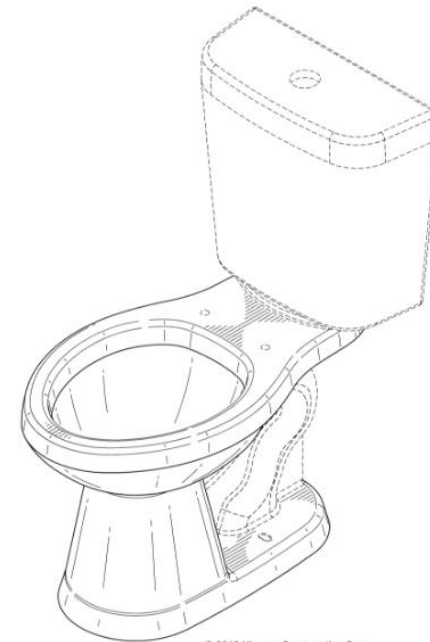

© 2012 Niagara Conservation Corp.



Design Patent

Consumer Products

[US D704316](#)

Toilet

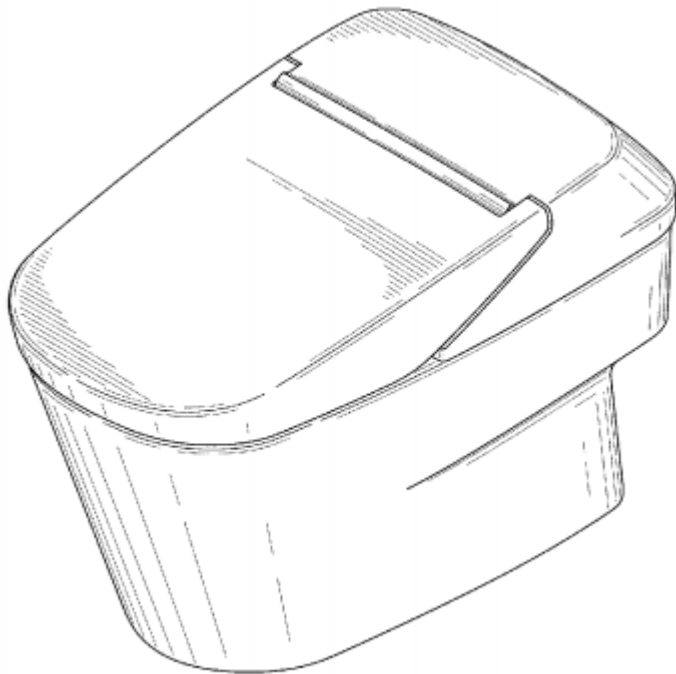

[US D649728](#)

Disposable paper trash bin

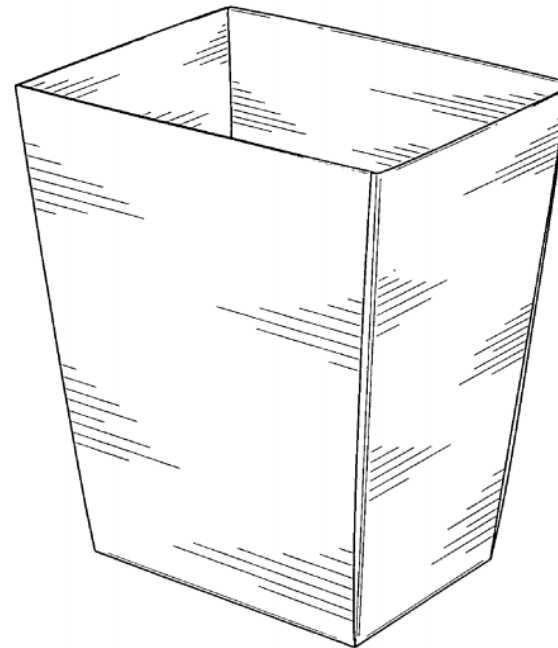

Design Patent

Graphical User Interface

[US D604305](#)

Graphical user interface for a display screen or portion thereof

(Apple Inc.)



[US D653258](#)

Display panel of a programmed computer system with a graphical user interface

(Facebook Inc.)

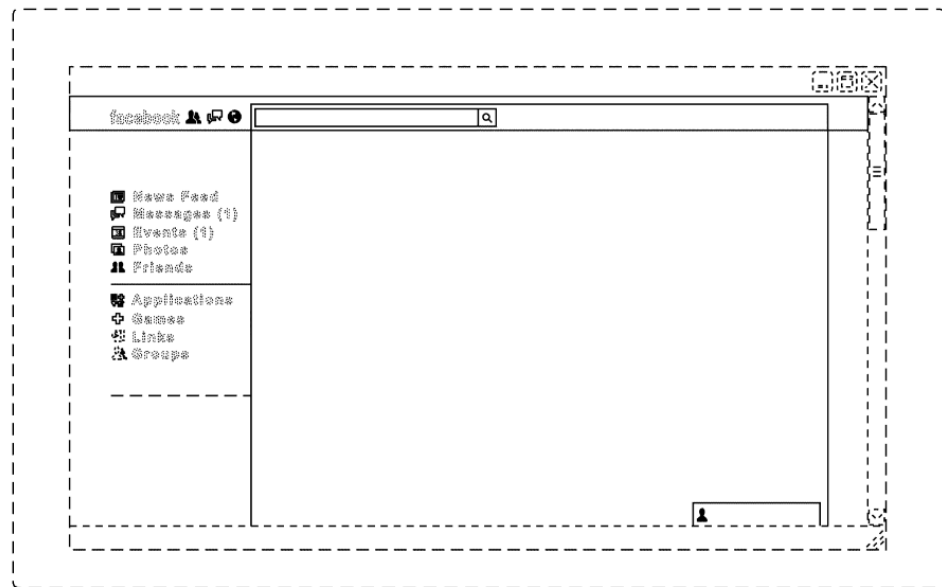

Design Patent

Graphical User Interface

[US D599372](#)

Graphical user interface for a display screen of a communications terminal

(Google Inc.)

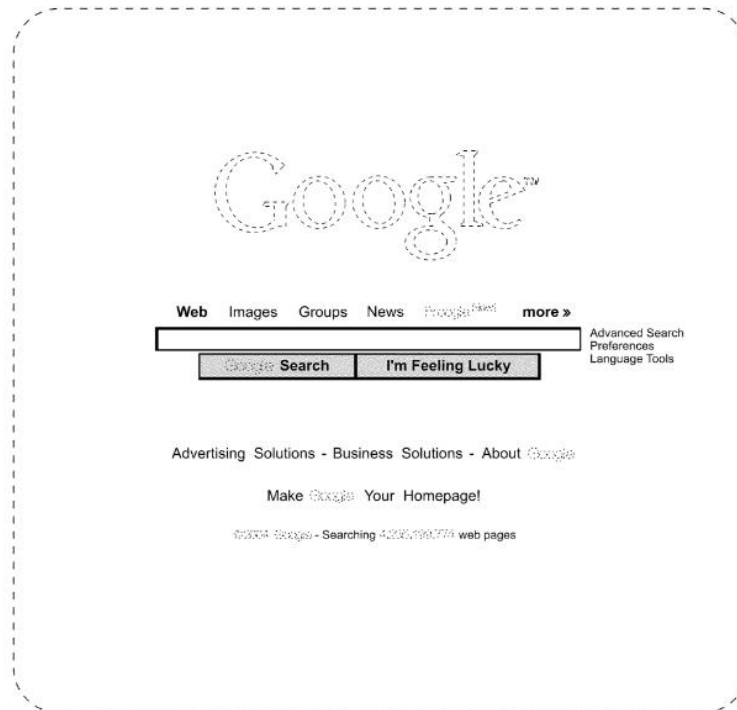

Design Patent

Construction

[US D478999](#)

Glass support member

(Apple Computer, Inc/Steve Jobs etc.)

See also: [US 7165362](#)

Glass support member

(Apple Computer, Inc/Steve Jobs etc.)

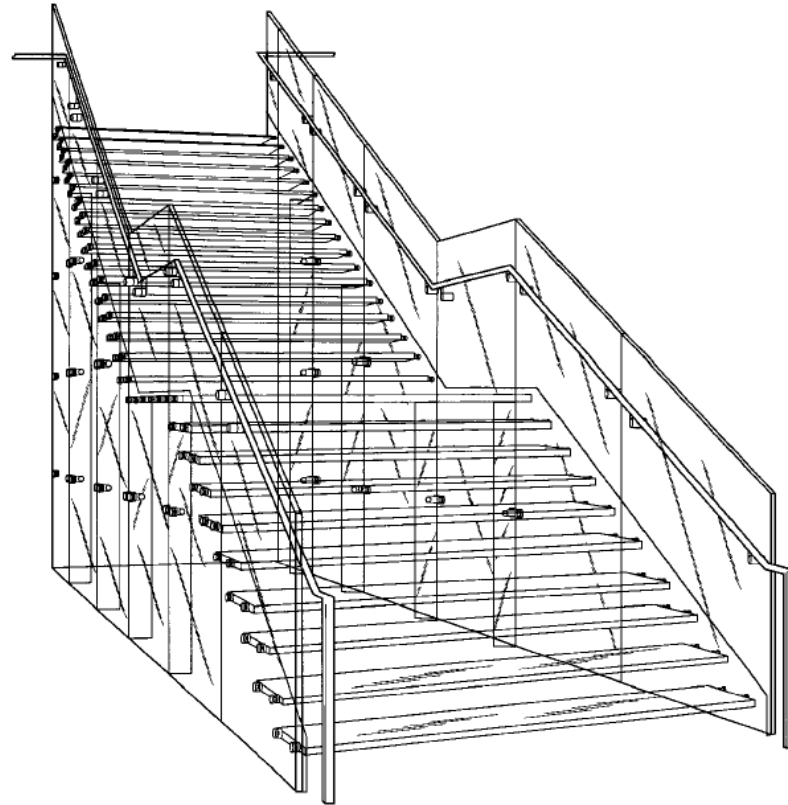

Design Patent

Construction

[US D715963](#)

Staircase

(Apple Inc)

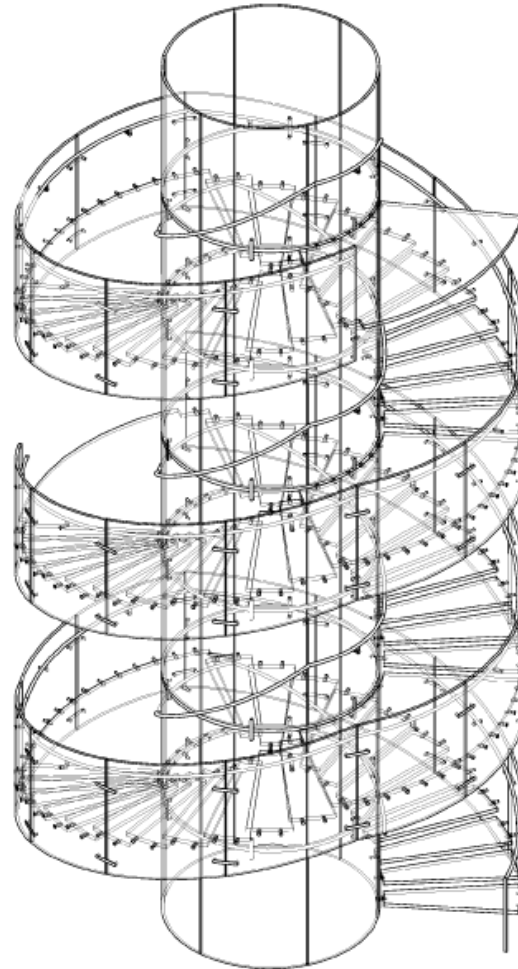



4. Patent Prosecution

General Patent Prosecution Procedure

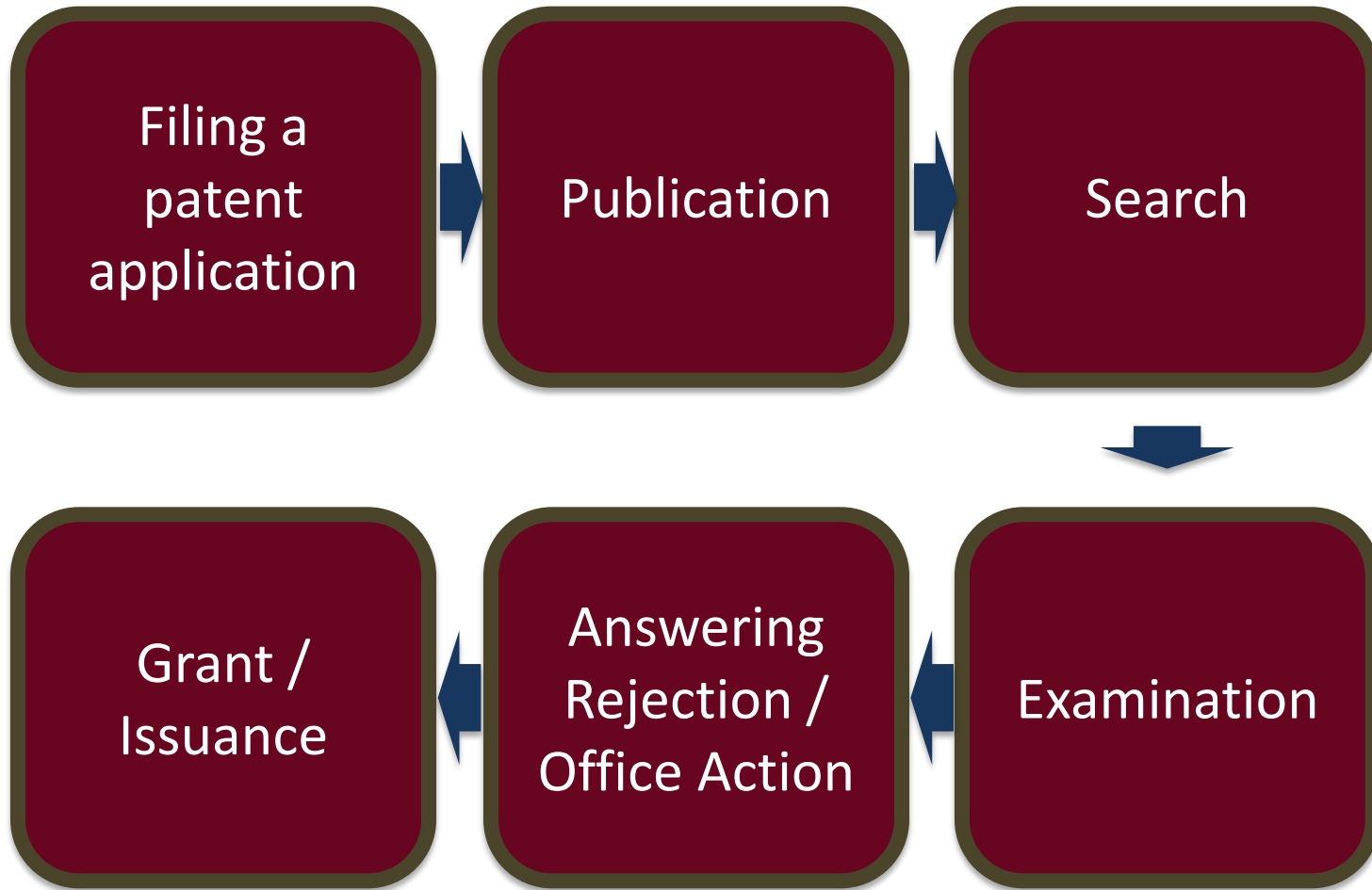



General Patent Prosecution Procedure

- Anytime before issuance of a patent application...
- **Divisional Application**
 - (Similar to) continuation / continuation in part
 - Only one invention per application (because of \$)
 - Inventor/applicant would still have priority rights in matter disclosed in the parent application
 - The “dragging” of priority

General Patent Examination Standards

- **What matters most?**
 - Claims (and their support)
- **Where matters most?**
 - The public domain
- **Who matters most?**
 - The skilled person in the art
- **When matters most?**
 - The priority date

(19)  (11)  EP 1 887 187 B1

(12) **EUROPEAN PATENT SPECIFICATION**

(45) Date of publication and mention of the grant of the patent:
30.04.2014 - Bulletin 2014/18 (51) Int. Cl.:
F01D 5/28 (2006.01) F02K 3/04 (2006.01)

(21) Application number: 07113169.2
(22) Date of filing: 26.07.2007

(54) **Rotor blade**
Rotorschaukel
Aube de rotor

(64) Designated Contracting States:
DE FR GB (74) Representative: Illingworth, William
Illingworth
GPO Europe
GE International Inc.
The Ark
201 Talgarth Road
Hammersmith
London W6 8BJ (GB)

(30) Priority: 31.07.2006 US 461014
(43) Date of publication of application:
13.02.2008 Bulletin 2008/07 (56) References cited:
FR-A1- 2 874 232 GB-A- 1 500 776
GB-A- 2 262 315 US-A- 5 279 892
US-A1- 2003 017 053 US-A1- 2006 120 874
US-B1- 6 431 837

(73) Proprietor: GENERAL ELECTRIC COMPANY
Schenectady, NY 12345 (US)
(72) Inventor: Schilling, Jan Christopher
Middletown, OH 45044 (US)

EP 1 887 187 B1

Note: Within nine months of the publication of the mention of the grant of the European patent in the European Patent Bulletin, any person may give notice to the European Patent Office of opposition to that patent, in accordance with the Implementing Regulations. Notice of opposition shall not be deemed to have been filed until the opposition fee has been paid. (Art. 99(1) European Patent Convention).

Printed by Jouve, 15021 PAVIS (FR)

General Patent Examination Standards

- **Novelty**

$$P_1 = C$$

- **Inventiveness**

$$P_1 + P_{(x)} = C$$

- **Industrial Applicability**

- Can be made or used in some kind of industry

- **Sufficient Disclosure**



Major International Frameworks

- Patent is “local” – protection must be sought separately for each country, but...
- **Paris Convention**
 - 177 countries
 - Recognition of priority based on a filing in a member state
- **Patent Cooperation Treaty (PCT)**
 - 152 countries
 - Extended period for recognition of priority
 - International stage and national stage
- **European Patent Office (EP)**
- **Gulf Cooperation Council (GCC)**



Major International Framework

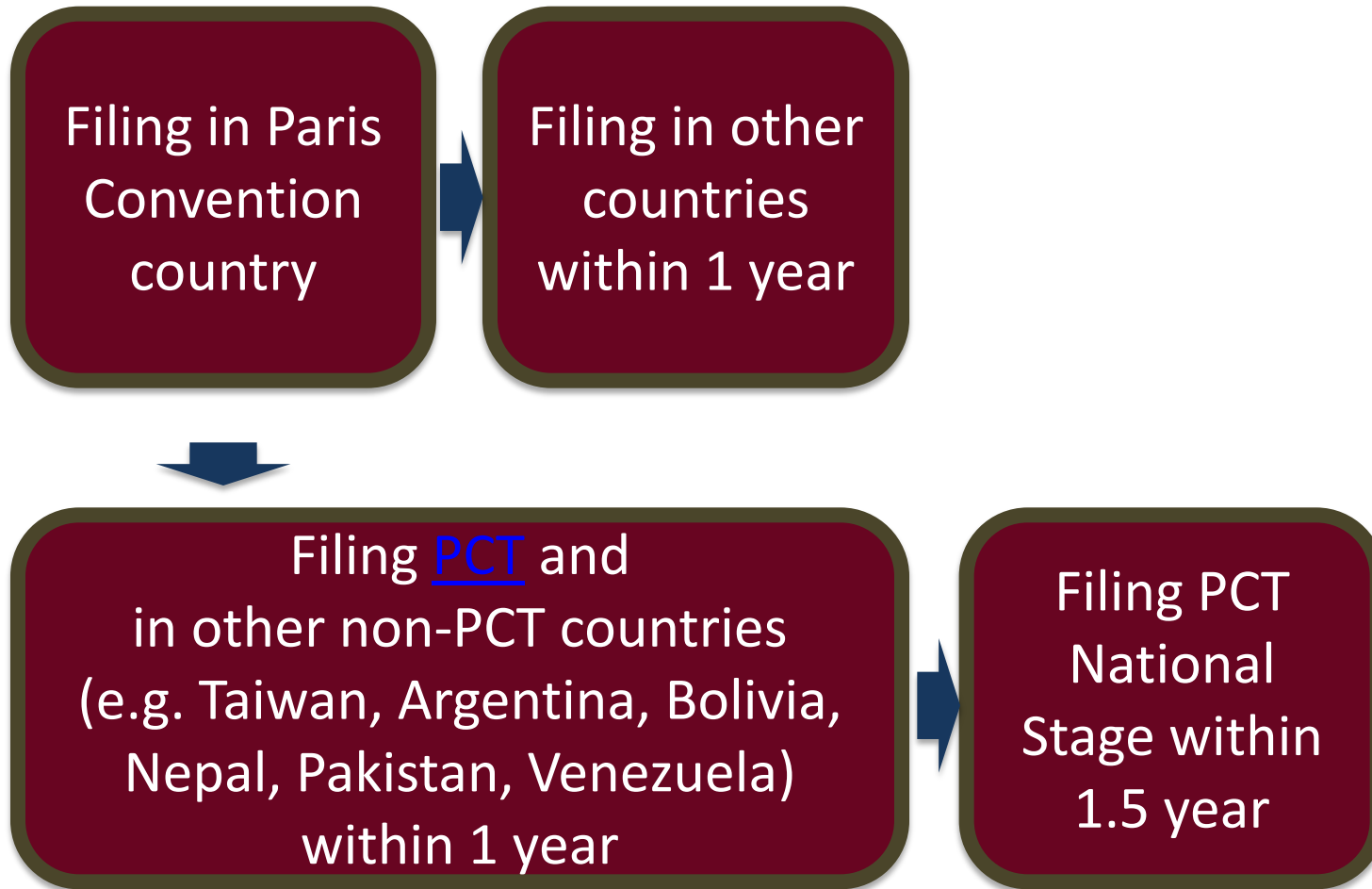

Patent Registration Procedure in Hong Kong

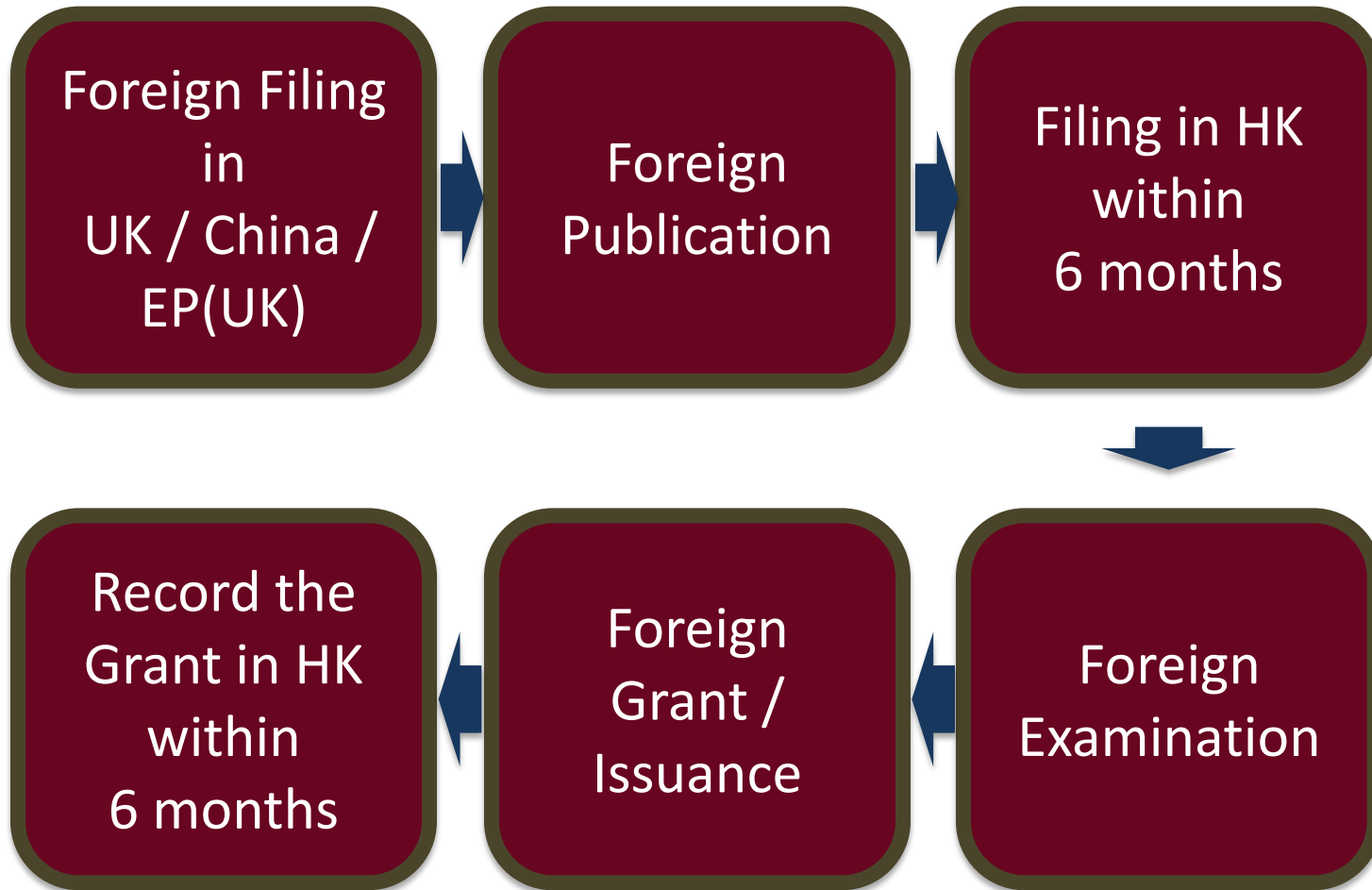



5. Worldwide Strategy

Worldwide Strategy

Where to file?

- Points of sale
- Points of manufacturing
- Points of shipment (only for some countries)
- Potential markets (of your product & your technology)
- All of the above of your competitors



Worldwide Strategy

Where to file first?

- Nationality of the inventor/applicant
- Major market
- Quality and delay of examination
- Filing and translation costs





6. Patent Portfolio

Building a Patent Portfolio

People: Protect the work made for hire

- Non-disclosure agreement
- Assignment agreement
- Bonus scheme

Policy/System: Encourage submission of idea

- Regular internal IP review to identify technical advantages
- Regular review of competitors' activities
- **Clearance search** before production
- IP review before launching of product or publication
- Proper recording of all research and development activities

Building a Patent Portfolio

Action:

File applications



Managing a Patent Portfolio

Pre-filing

- Novelty search, pick the game worth fighting
- Sufficient disclosure

Prosecution

- Get what you can
- Keep up with deadlines

Post-rejection / Post-allowance

- Divisional
- Any defects?



Managing a Patent Portfolio

Post issuance

- Pay annuity (or not)
- Seek licensing / co-operation opportunities
- Make further improvement
- Share the knowledge with other departments/businesses
- Oppose to “design around” application





7. Cost-saving Tips

Cost-saving Tips

Pre-filing

- Novelty search, pick the games that are worth fighting
- Quality check – substance and procedural
- Intentional divisional
- Drag the priority by filing PCT/EP

Prosecution costs

- Centralize management of all prosecutions, one size sometimes fits all
- Request PCT examination
- Withhold examination in less important countries
- Request PPH after favorable examination result (only in applicable countries)



Cost-saving Tips

Dealing with rejections/office actions

- Request phone interview with examiners, minimize writing
- Copy

Post-allowance

- Post allowance review before issuance
- Check the claims

Post-issuance

- Pay annuity only if you need it



8. Defence and Enforcement

Defence

Patent is not a licence to infringe

- But in business, it can become your bargaining chips

Ride on competitor's mistakes

- When competitor claims a broad and general invention
- You may claim a narrow and specific invention that the competitor has failed to disclose
- Blocking effect

Defend your invention from infringers



Enforcement

Monitor competitors' activities

- From what the competitors sell
- From what the competitors file

Notify potential infringers

- Issue cease and desist letter upon knowledge of potential infringement
- Evidence for the infringer's willful infringement (triple/punitive damages in some countries)
- But in HK: Groundless threats of infringement proceedings

Enforcement may lead to cooperation/settlement



Questions?

1. [What is a patent?](#)
2. [The protection and value conferred by a patent](#)
3. [What can you patent for your business?](#)
4. [Elements of a patent prosecution](#)
5. [Worldwide strategy](#)
6. [How to build and manage a patent portfolio for your business?](#)
7. [Cost-saving tips in patent prosecution](#)
8. [Defence and enforcement](#)



Happy Holiday
Thank you

ONC Lawyers

柯伍陳律師事務所

19th Floor, Three Exchange Square
8 Connaught Place, Central, Hong Kong
Tel: (852) 2810 1212
Fax: (852) 2804 6311
Email: ip@onc.hk
Website: www.onc.hk



Primerus
Member



LEADING FIRM

Important: The law and procedure on this subject are very specialised and complicated. This seminar is just a very general outline for reference and cannot be relied upon as legal advice in any individual case. If any advice or assistance is needed, please contact our solicitors.

solutions • not complications